

 **PENTAIR**
AQUATIC SYSTEMS

PANTERA® EVOLUTION



PANTERA® EVOLUTION

DUAL SPEED POOL PUMP



ENERGY-SAVING REVOLUTION...

AN ECO SELECT® BRAND PRODUCT

The Eco Select brand identifies our "greenest" and most efficient equipment choices.

By combining efficient pump design with game-changing dual speed technology, the PANTERA® EVOLUTION delivers great energy savings while reducing noise pollution and the consumption of valuable resources.



Intuitive Electronic Control - Easy to use speed selection with two fixed speeds, automatic High-Speed Priming, boost mode and sync mode.

Swivel Barrel Unions - Pump fits to existing plumbing with ease with its quick connecting swivelling barrel unions.

High Efficiency Dual Speed Motor - Totally enclosed fan cooled design keeps motor shielded from the elements for extended life.

Innovative hydraulic isolator separates priming water from pumping water, for faster priming and greater efficiency.

New sound dampening elevated motor base.

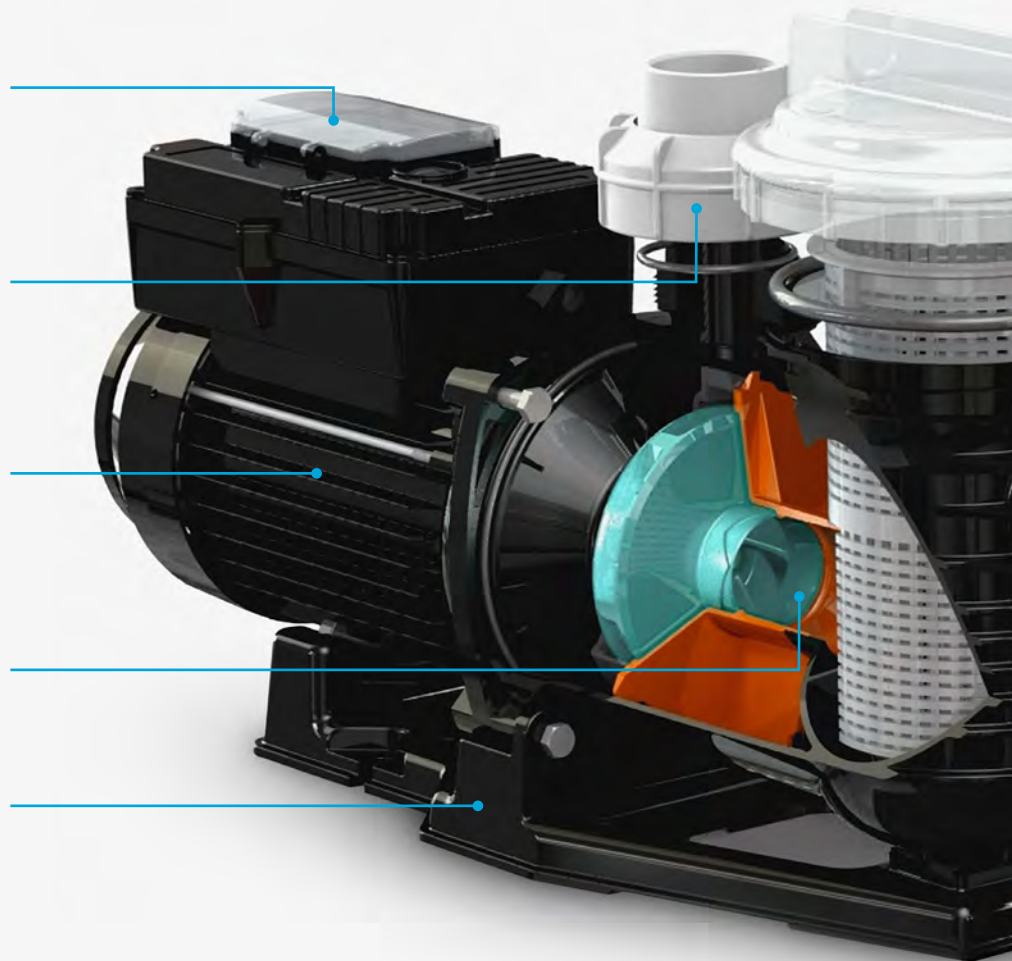

WITH RESPECT TO THE ENVIRONMENT

THE GREEN...ENERGY SAVER...

The new PANTERA® EVOLUTION is the ideal pump for new or existing pools. Utilising efficient hydraulic design and the latest technology in electronic control two speed motors, the EVO` has the perfect combination of efficiency and performance.

The EVO` delivers energy savings for a realistic cost outlay and the power when you need it. You will also have the peace of mind that you are doing your bit for the environment and reducing your carbon foot print. The EVO` is a direct drop in replacement for the thousands of LTP and PPP series of pumps in use today.



THE BENEFITS OF VARIABLE SPEED & STEP TECHNOLOGY

By halving the speed of your pool pump and increasing the run time you might be surprised to learn that you will filter the same volume of water up to 4 times more efficiently. By running the PANTERA® EVOLUTION at low speed whilst filtering your pool, you can save over 60% of your pool pump running costs, reducing the cost of pool ownership whilst doing your bit to help the environment.

The EVO` also utilises electronic control which adds improved functionality over other pumps.

High-speed priming runs the pump at high speed for the first 2 minutes to ensure the pump is primed and ready, before automatically switching to low speed and saving money while you filter.

High-speed Boost mode runs the pump at high speed for 2 hours to give you time to vacuum your pool, run a suction cleaner, or super-chlorinate and the pump will automatically switch back to low, so don't worry about forgetting!

Sync Mode will alternately start the pump in high and low speeds, allowing you to program high-speed and low-speed cycles with your time clock.

Also remember you can change speed at any time, with the touch of a button.

SLASH ENERGY USE BY OVER 60% AND SAVE

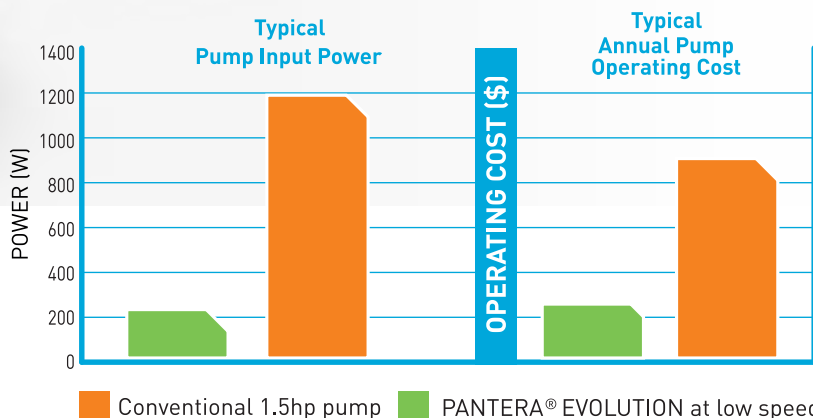

PANTERA® EVOLUTION

DUAL SPEED POOL PUMP

PANTERA EVO	LOW	HIGH
RPM	1450	2800
Max. motor input power P1	223W	1180W
Max. motor output power P2	118W	950W
Max. Current	1.0A	5.2A
Voltage	230-240VAC 50Hz Single phase	
IP Rating	IP25	
Motor type	TEFC • 2 pole / 4 pole induction motor	
Inlet connection	PVC Barrel Union to suit 40mm PVC pressure pipe to AS/NZS 1477 or 50mm spigot	
Outlet connection	PVC Barrel Union to suit 40mm PVC pressure pipe to AS/NZS 1477 or 50mm spigot	
Max. Total head	20m	
Water temperature range	5°C - 40°C	
Max. Ambient temperature	55°C	
Recommended pH range	7.2 - 7.8 (guide only)	
Sound power level (Lwa)	53dB	69dB
Max. recommended pool size	50,000L	
Max. recommended sand filter size	Sand: 25"	Cartridge: No limit
Max. recommended suction lift	1m	

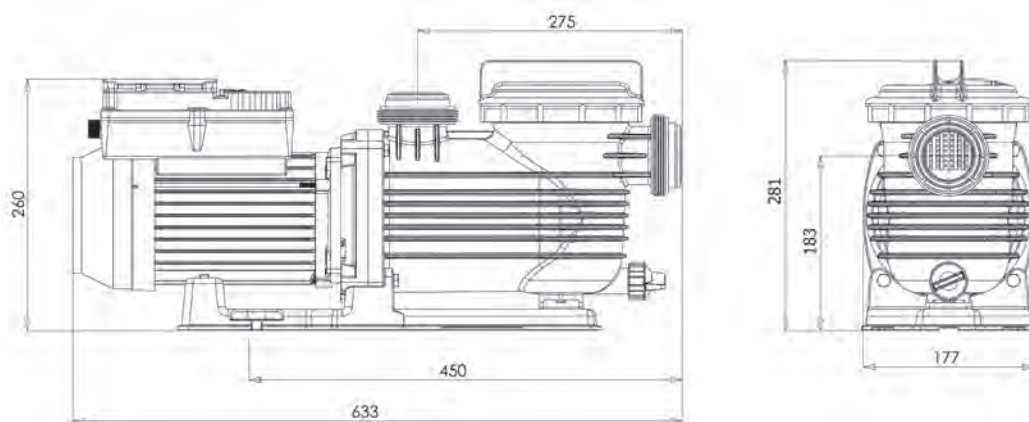
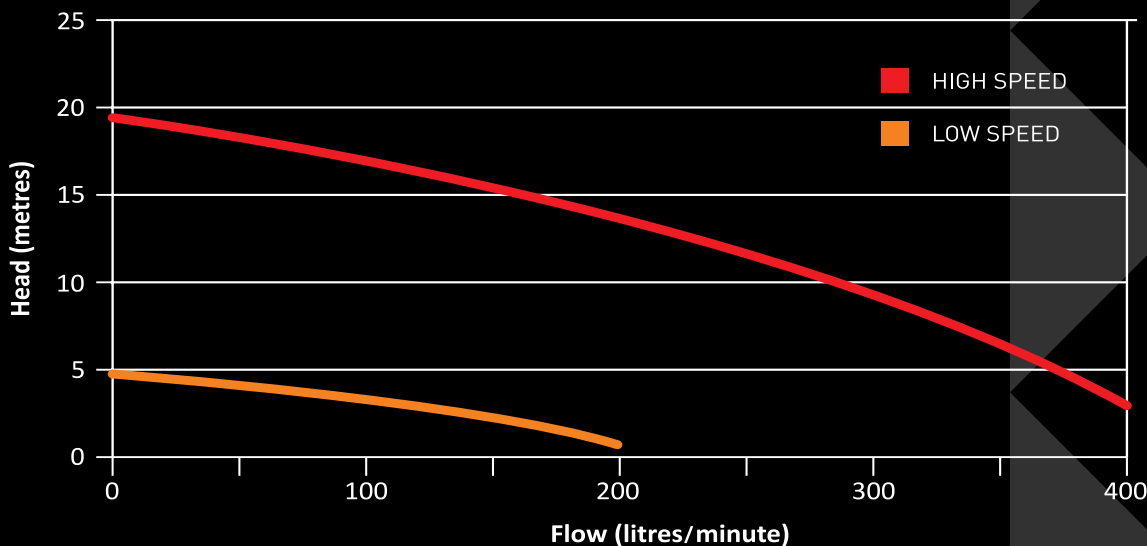

1-21 MONASH DRIVE, DANDENONG SOUTH, VIC 3175 • 1300.137.344 • WWW.PENTAIRPOOL.COM.AU

All Pentair trademarks and logos are owned by Pentair or one of its global affiliates. Torpedo® is a registered trademarks of Pentair Water Pool and Spa, Inc. and/or its affiliated companies in the United States and/or other countries. Because we are continuously improving our products and services, Pentair reserves the right to change specifications without prior notice. Pentair is an equal opportunity employer.

pumps • filters • heaters • heat pumps • automation • lighting • cleaners • sanitizers • water features • maintenance products

L300268 A0616 - Copyright © Pentair Australia Pty Ltd 2016. All rights reserved.



Freephone 0508 634 341 | Fax 09 634 7417

7 Monier Pl, Mt Wellington, Auckland 1060, New Zealand