



KD Series

The Davies Pumps KD model is a rugged cast iron single impeller pump with close coupled motor design for simple and reliable operation. Closed impeller design with powerful single phase motor and 2" ports makes these an ideal wash down or transfer pump where three phase power is not available.

Pump Features

- Cast Iron Housings
- Single impeller
- Robust and reliable
- Maximum liquid temperature 90 degrees
- Flows up to 500lpm
- Pressure up to 33m

DAVIES KD SERIES

Part No.	HP	kW	Phase	Volts	Amps
220-KD300M	3.0	2.2	1	230	13

FARMING



INDUSTRIAL



WATER TRANSFER



KD SERIES

Performance:

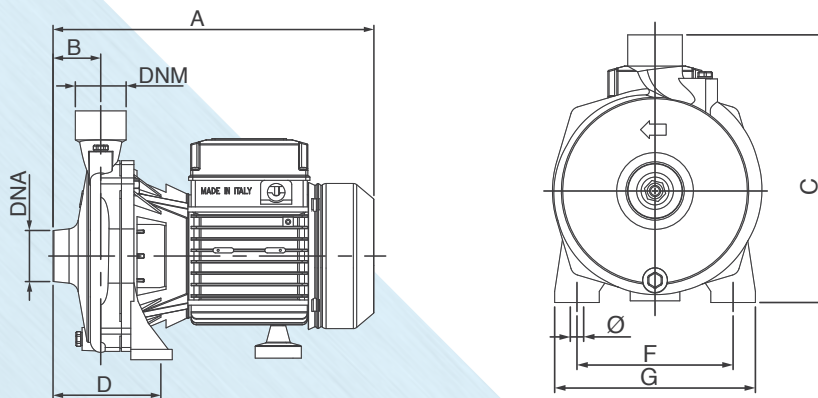
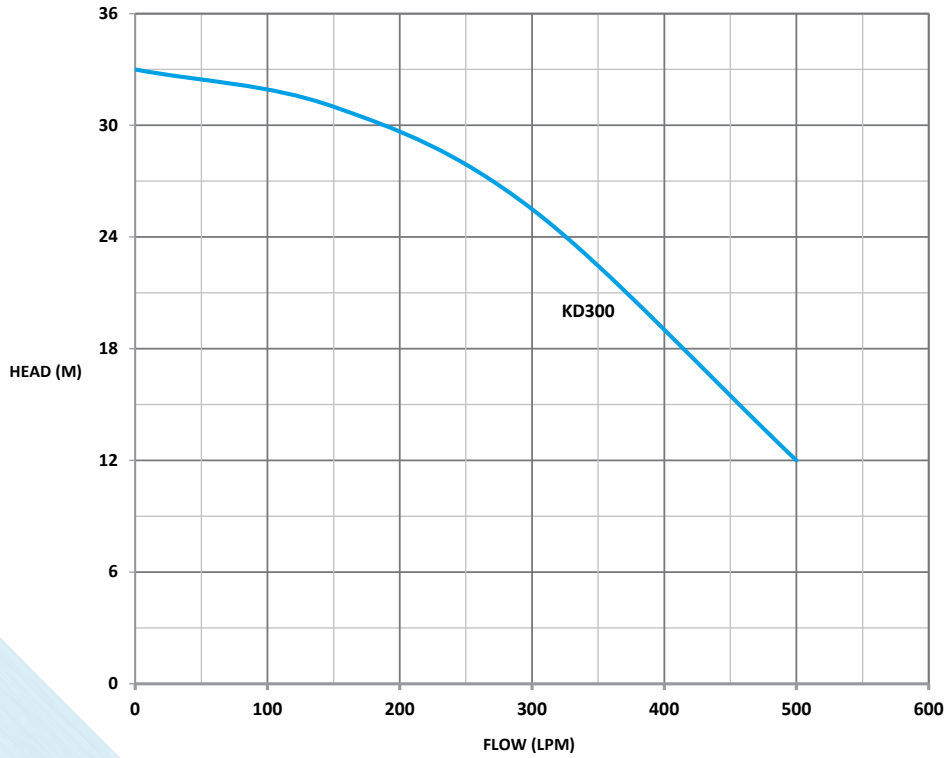

DIMENSION AND SPECIFICATIONS

Model	A	B	C	D	F	G	Ø	H	DNA	DNM	Kg
KD300M	365	52	295	149	190	240	11	125	2"	2"	31.5